

EMERGENCY SHUTOFF AND FIRESAFE VALVES

FIGURE 1075

The Jamesbury FM (Factory Mutual) approved Emergency Shutoff and Firesafe Valves Figure 1075 are manual assemblies consisting of the Jamesbury Fire-Tite® valves and the Jamesbury Torque Handles®. These assemblies provide automatic closure of a normally open valve in the event of a fire or excessive temperature. These assemblies are used for all types of media including flammable gases, liquids, and toxic fluids.

Figure 1075 assemblies carry FM approval as Firesafe Valves, specifically designed for flammable liquid service. To meet the requirements of this category, the Jamesbury *FIRE-TITE* valves have been tested and qualified to resist direct exposure typical of uncontrolled fire for at least 15 minutes.

Included in the line of Figure 1075 Emergency Shutoff Valve assemblies are 1/2"-2" (DN 15-50) Series 5150 flanged ball valves and 1"-2" (DN 25-50) Series 2000 Clincher® screwed-end ball valves equipped with *TORQ-HANDLE* spring-return handles and a choice of fusible links for specific temperature requirements.

FEATURES

- Automatic closure in the event of a fire.
- FM approved for Emergency Shutoff service.
- FM approved as Firesafe Valves for flammable liquid service.
- Quarter-turn operation for quick shutoff in the event of an emergency.
- Flexible-lip seat design for reliable long-lasting sealing.
- PTFE seats and seals for easy cycling, even when operated infrequently.

ACCESSORIES

Limit switches can be provided for remote indication of valve position or for various electrical interlocks. Switch arrangements available with these assemblies are:



Designation	Switch Type	Enclosure
EW2	(2) SPDT	Dusttight, Watertight ¹
32EX6	(2) SPDT	Watertight, Hazardous Location ²
34EX6	(2) DPDT	Watertight, Hazardous Location ²

Note 1: Meets NEMA 4 specifications.

Note 2: Meets NEMA 4, 7 - Groups C and D, and 9 - Groups E, F, and G specifications.

Unless otherwise specified, assemblies with limit switches are adjusted at the factory so that one switch is actuated when the valve is closed, and the other when the valve is fully open.

Spring-return handles may be specified with optional accessories when FM approval is not a consideration. Locking devices to padlock the handle in position or electrothermal links to allow connection to a remote device like a smoke or heat detector are available. See Bulletin B160-1 for non-FM-approved standard spring-return handles and various accessories.

SPECIFICATIONS

Valve Seat Ratings

Seat ratings, indicated by solid lines in the charts, are based on differential pressure with the valve ball in the fully closed position and refer to seats only. In the charts below the dotted lines indicate maximum working pressures for carbon steel valve bodies. Maximum working pressure of 316 stainless steel bodies are shown below. The combination of dotted and solid lines indicates the

maximum valve rating at specific pressure and temperature conditions. Valves with PTFE, XTREME™ and filled PTFE seats can be used in service to -60°F (-51°C) provided the valve body material and body fasteners are suitable for such temperatures. **Note:** Fasteners for FM-approved Series 2000 valves are rated for -20°F only.

1"-2" (DN 25-50) Series 2000 Valves

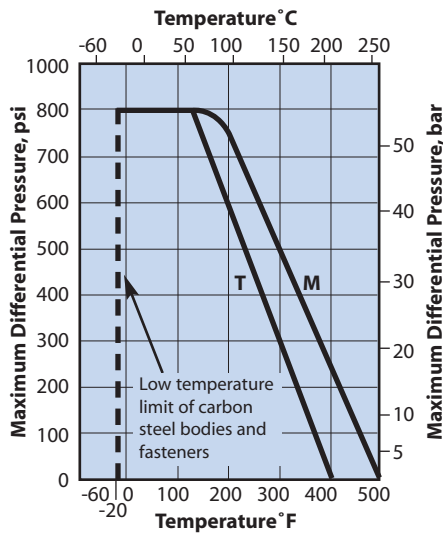

1/2"-2" (DN 15-50) Series 5150 Valves

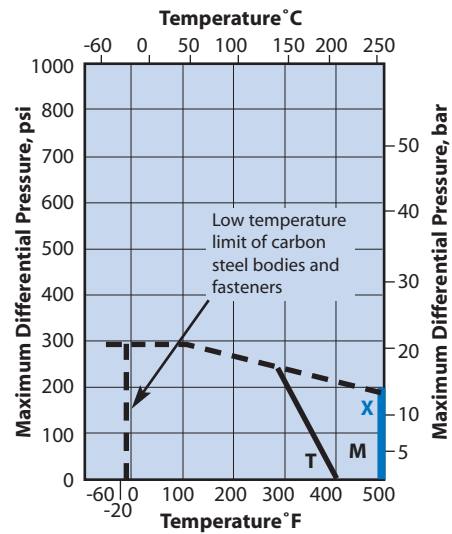

T - PTFE M - Filled PTFE X - XTREME

VALVE BODY RATINGS

These are maximum working pressure ratings of the valve body only. The seat ratings, shown above, determine the practical pressure limitations according to actual service conditions. Test pressures are for hydrostatic test with ball half open.

1"-2" (DN 25-50) Series 2000 Valves Body Ratings				
Parameter	°F	°C	Carbon Steel or 316 Stainless Steel Body with ASTM A193 Gr. B7 Body Bolts	
			psi	bar
Working pressure	-20 to +100	-29 to +38	800	55
Test pressure			1200	83

1/2"-2" (DN 15-50) Series 5150 Valves Body Ratings						
Parameter	°F	°C	Carbon Steel		316 Stainless Steel	
			psi	bar	psi	bar
Working Pressure	-20 to +100	-29 to +38	285	20	275	19
	200	93	260	18	240	17
	300	149	230	16	215	15
	400	214	200	14	195	13
	500	260	170	12	170	12
Test Pressure			450	31	425	29

FLOW DATA

The tables to the right provide flow coefficients for JAMESBURY valves covered in this section. The Cv values represent the flow of water at +60°F through the valve in U.S. gallons per minute at a pressure drop of 1 psi. The metric equivalent, Kv, is the flow of water at 16°C through the valve in cubic meters per hour at a pressure drop of 1 kg/cm³. To convert Cv to Kv, multiply by 0.8569

Series 2000 Valves		
Valve Size		Cv
Inches	DN	
1	25	49
1-1/4	30	49
1-1/2	40	100
2	50	115

Series 5150 Valves		
Valve Size		Cv
Inches	DN	
1/2	15	9
3/4	20	19
1	25	45
1-1/2	40	125
2	50	165

DIMENSIONS

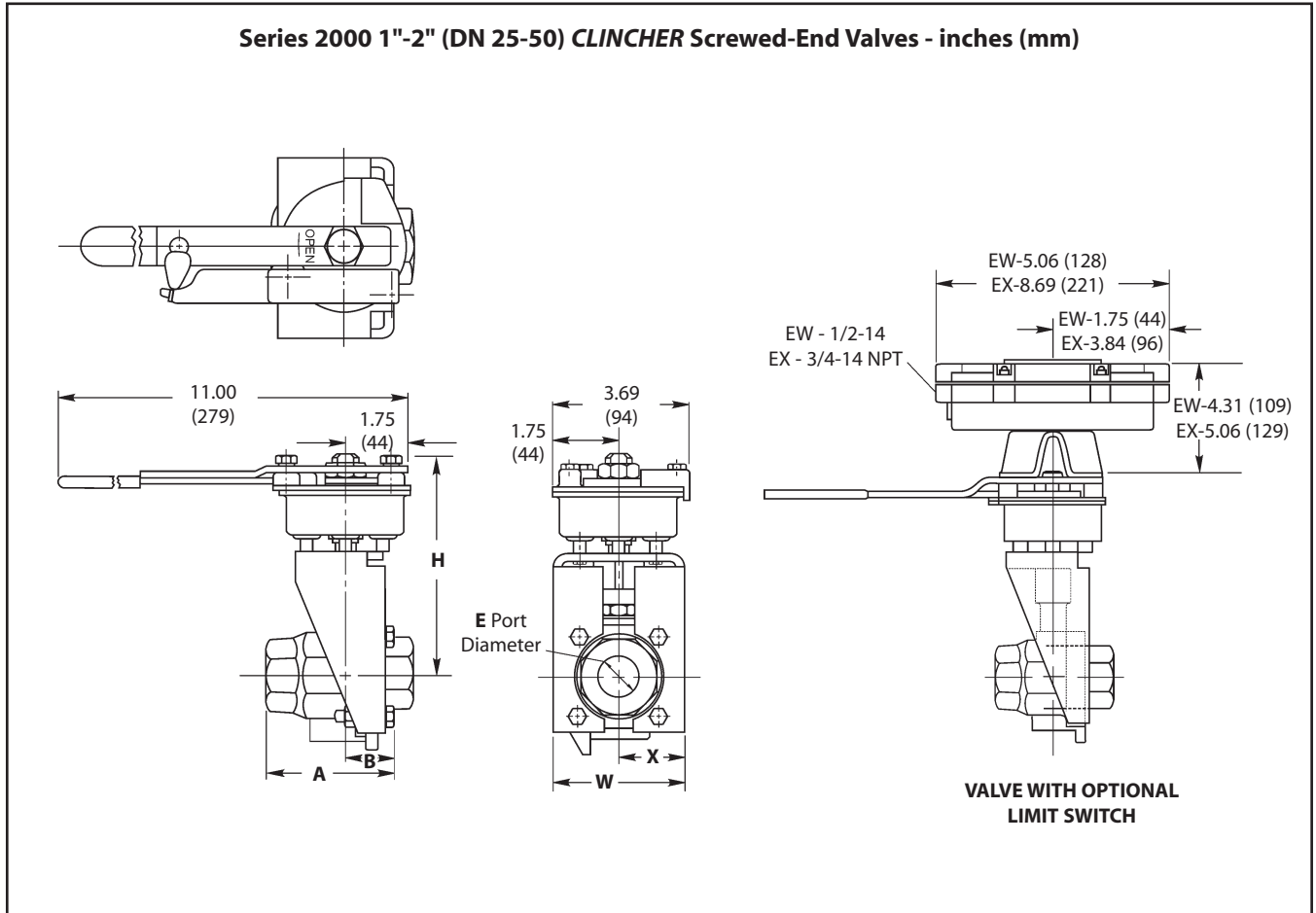

Approximate Dimensions - inches							
Valve Size inches	A	B	W	X	E	H	Approx. Weight lb.
1	3.41	1.70	3.63	1.81	0.88	6.13	7.6
1-1/4	3.75	1.88	3.63	1.81	1.00	6.25	9.2
1-1/2	4.03	2.02	3.88	1.94	1.25	6.75	11.3
2	4.38	2.19	4.25	2.13	1.50	7.00	13.3

Approximate Dimensions - mm							
Valve Size DN	A	B	W	X	E	H	Approx. Weight kg.
25	87	43	92	46	22	156	3
30	95	48	92	46	25	159	4
40	102	51	99	49	32	171	5
50	111	56	108	54	38	178	6

DIMENSIONS

Series 5150 1/2"- 2" (DN 15-50) ANSI Class 150 Flanged Valves - Inches (mm)

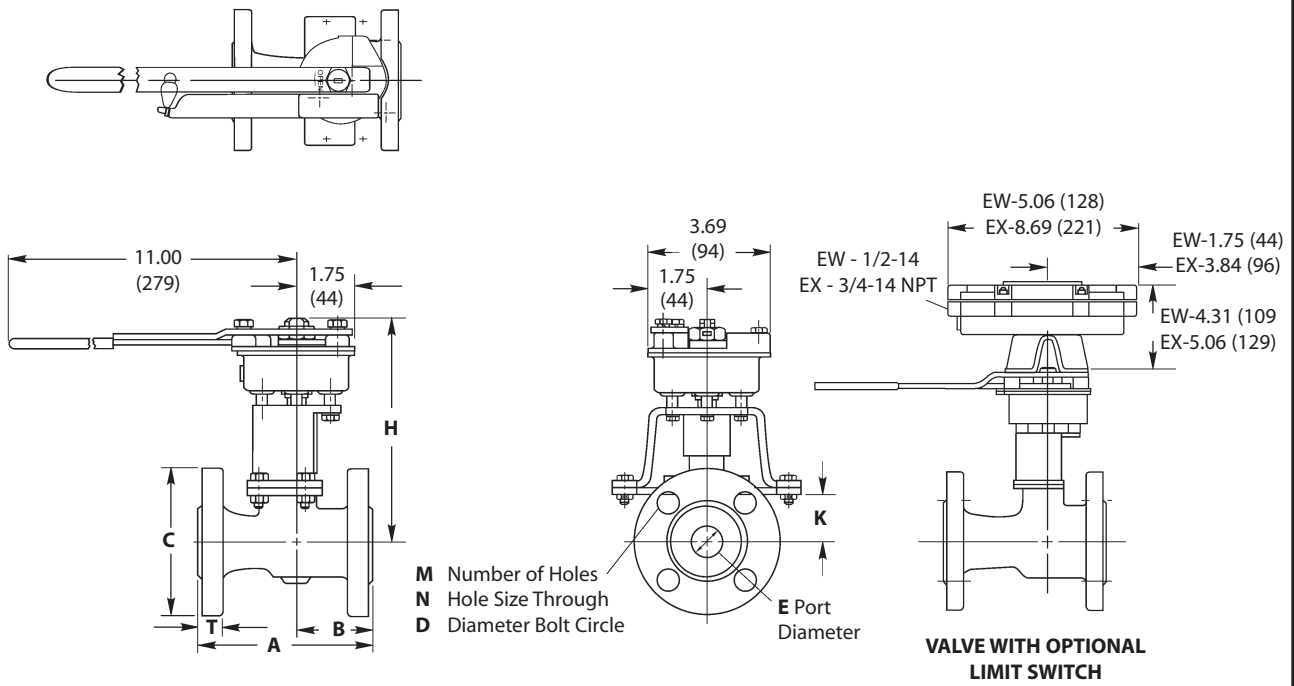

Approximate Dimensions - inches

Valve Size inches	A	B	C	D	E	H	K	M	N	T	Approx. Weight lb.
1/2	4.25	1.81	3.50	2.38	0.50	6.25	0.88	4.00	0.63	0.44	8.1
3/4	4.63	2.00	3.88	2.75	0.68	6.38	1.00	4.00	0.63	0.44	9.1
1	5.00	2.19	4.25	3.13	0.88	6.88	1.38	4.00	0.63	0.63	12.9
1-1/2	6.50	2.44	5.00	3.88	1.25	7.75	2.19	4.00	0.63	0.63	16.5
2	7.00	2.44	6.00	4.75	1.50	7.88	2.38	4.00	0.75	0.69	21.1

Approximate Dimensions - mm

Valve Size DN	A	B	C	D	E	H	K	M	N	T	Approx. Weight kg.
15	108	46	89	60	13	159	22	102	16	11	4
20	118	51	99	70	17	162	25	102	16	11	4
25	127	56	108	30	22	175	35	102	16	16	6
40	165	62	127	99	32	197	56	102	16	16	7
50	178	62	152	121	38	200	60	102	19	18	10

HOW TO ORDER EMERGENCY SHUTOFF AND FIRESAFE VALVES

The designation for Emergency Shutoff Valves is made up of numbers and letters that fully describe all features of the available variations of these units. Coding is as follows:

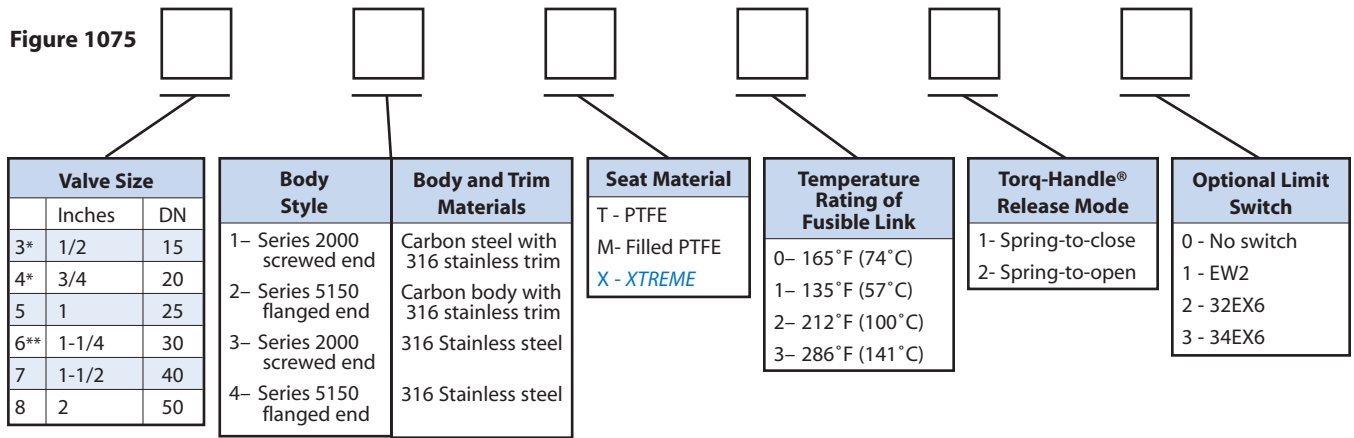

* Series 5000 valves only

** Series 2000 valves only

Example: A 1-1/2" (DN 40) Emergency Shutoff Valve Assembly Series 2000, screwed end in carbon steel with 316 stainless trim and PTFE seats with +165°F (74°C) fusible link and TORQ-HANDLE set for spring-to-close operation without limit switches is designated as Figure 1075-71T010.

Available Sizes by Valve Type and Seat Material				
Style	X* and T Seats		M Seats	
	Inches	DN	inches	DN
2000	1-2	25-50	1-1-1/4	25-30
5150				
5150	1/2-2	15-50	1/2-1	15-25

* Series 5000 valves only

Installation Instructions, Maintenance and Operation

IMO's (Installation, Maintenance and Operating instructions) are shipped with the products. Additional copies of these instructions are available. Call your local Metso Automation Distributor, or visit our website.

Metso Automation, Field Systems Division

Europe, Levytie 6, P.O.Box 310, 00811 Helsinki, Finland. Tel. int +358 20 483 150. Fax int. +358 20 483 151

Europe (UK), 8 Pipers Wood Industrial Park, Waterlooville, Hampshire PO7 7XU UK. Tel. int +44 (0)23 9223 8500. Fax int. +44 (0)23 9223-8510

North America, 44 Bowditch Drive, P.O.Box 8044, Shrewsbury, Massachusetts, 01545-8044 USA. Tel. int. +1 508 852 0200. Fax int. +1 508 852 8172

North America, 3100 Medlock Bridge Road, Suite 250, Norcross, GA 30071, USA. Tel. int. +1 770 446 7818. Fax int. +1 770 242 8386

Latin America, Av. Central, 181- Cháracas Reunidas, 12238-430, São Jose dos Campos. Tel. int. +55 12 335 3500. Fax int. +55 12 335 3535

Asia Pacific, 501 Orchard Road, #05-09 Wheelock Place, 238880 Singapore. Tel. int. +65 735 5200. Fax int. +65 735 2955

www.jamesbury.com • www.metsoautomation.com

